

# STL38

Turret type, sliding head machine (9-axis) with powerful Siemens 840D controller



Model	STL32/38	
	Y3	
NC	Siemens 840D	
Max. machining diameter (mm)	Ø32/38	
Z1 Stroke (mm)	320	
Main spindle	Speed (rpm)	6,500
	Motor (kW)	23
OD tool	No. of tools	5 (□16mm)
	No. of tools	4 (ER20M)
Cross drill	Speed (rpm)	6,000
	Motor (kW)	1.07
Turret unit	No. of unit	1 Unit (10 Station)
	No. of tools	max. 30 (□20mm, ER20)
	Tool type	VDI 30 (Option : BMT 45)
	Motor (kW)	2.59
Sub spindle	Speed (rpm)	6,500
	Motor (kW)	23
Back tool	No. of tools	8 (ER20M) (4 Fixed + 4 Driven)
	Speed (rpm)	6,000
	Motor (kW)	1.07
Machine size (L x W x H) (mm)	3,130 x 1,860 x 1,780	
Weight (kg)	4,500	
Power consumption (Cable size)	40kVA, 32kW (VCTF 16SQ x 4C)	
Air flow rate (Liter/Min)	20 ~ 30 (Hydraulic device capacity : 30L)	

## COMPLEX MACHINING

Combination of gang & turret unit and 3 path control system enables complex machining in various shapes

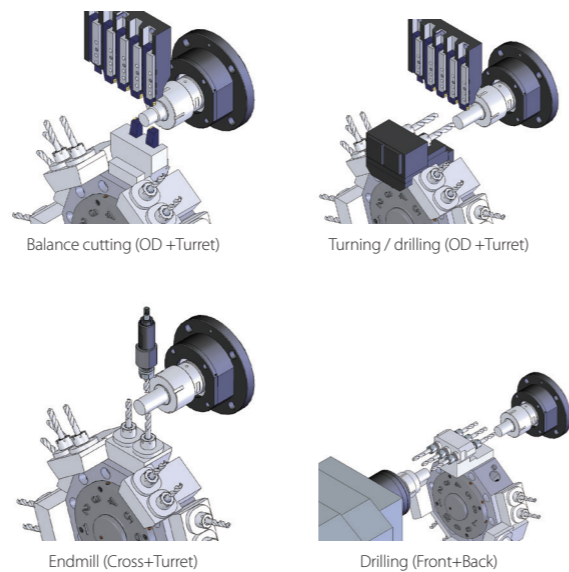

# Option Tooling

Max. 47 tools with gang & turret tool post are available, and customized high-complex tooling service is offered

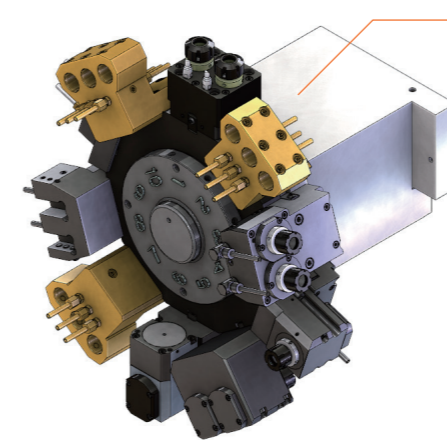

## Turret Unit

- Type of turret unit is selectable; VDI (standard) or BMT (Option)

### Specification

- 1 set turret (10 station)
- Tool holder type : VDI30, BMT45
- Tool size : □20, ER20
- Max. number of tools : 30

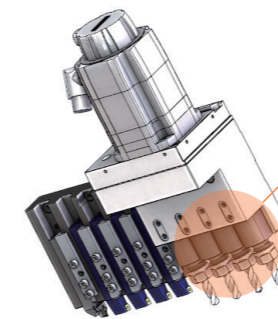
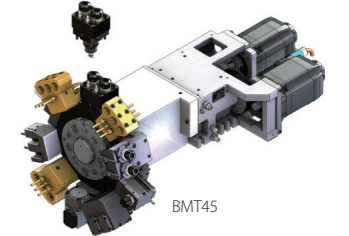
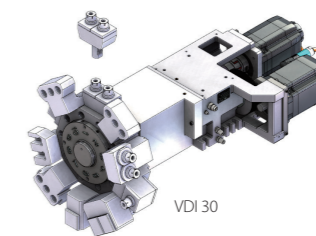

## Cross Drilling / Milling Unit

- Easy tool change for maintenance & installation

### Option tool

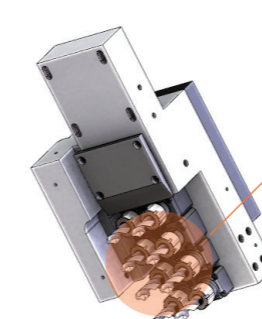

## Back Tool Unit

- Fixed 3 tools as standard and 8 tools of Y3 (4 driven, 4 fixed, ER20M) are available in modular type

### Option tool & unit

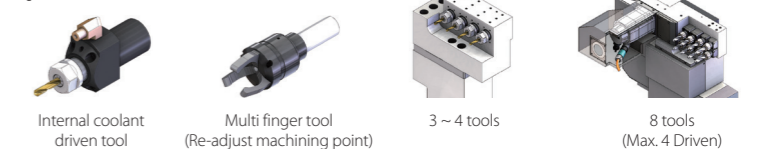

## Dimension

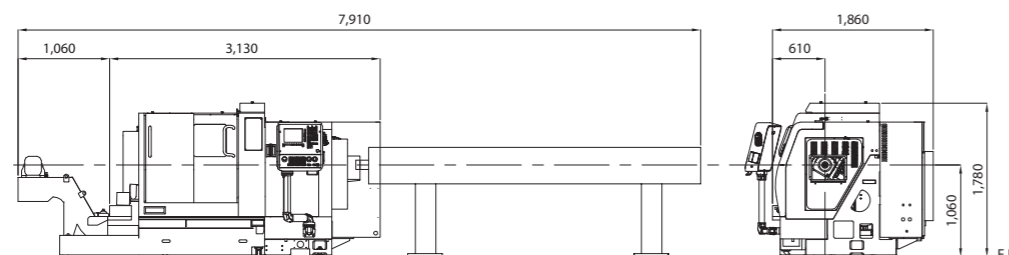

## Standard

- Main-Sub Cs control (0.001°)
- Rotary Guide bush holder
- MPG
- Chip conveyor
- Part conveyor
- Door interlock
- Work light
- Signal lamp (3color)
- Tool monitoring function
- Cut off tool breakage detector (S/W)
- Auto power off
- Bar feeder interface
- Middle pressure pump

## Option

- Bar feeder
- Transformer
- Tap breakage detector
- High pressure pump
- Oil mist collector
- Oil chiller
- Memory card
- Tooling & Programming
- Internal coolant driven tool (cross, back, off-center)
- NC warranty for 2 years
- Turret unit (BMT45)
- Turret Tool Holder